



DA2

Before we get into this super exciting user guide, we would just like to share a few words of appreciation

In a market dominated by generic designs, marketing fads and RGB lighting, we are on a mission to create products that are not just different for the sake of it, but incorporate quality materials, superior finishing, and innovate at every level. These qualities are not easily conveyed in an industry preoccupied with specs, numbers and flashing lights, so your choice shows an appreciation and understanding of what makes our products different, and we sincerely thank you for that.

We genuinely do our best to ensure that all our products are manufactured to the highest quality and finish we can achieve. If anything falls short of your expectations or you have any questions that are not covered in this user guide, please do not hesitate to get in touch with us online. We respond to every question or comment and your feedback is a critical part of our ongoing product development and of course our commitment to offer you the best service possible.

From everyone in the team, we hope that you have a great experience with this product :)

Table of Contents

| | | | |
|---|-------------------------------------------------------|----|--------------------------------------|
| 2 | Message, TOC, Introduction | 9 | Drive and PSU Brackets |
| 3 | Product Specifications & Overview | 10 | Fitting the PSU and Drive(s) |
| 4 | Removing Side Panels and Preparation for Installation | 11 | Connect the Front I/O Panel |
| 5 | Motherboard Options | 12 | Installing a PCI Expansion Card |
| 6 | Prepare and Install the Motherboard | 13 | Installing Vertical Bracket Hardware |
| 7 | Introduction to the Universal Bracket | 14 | Cooling Strategy / Integrated Nets |
| 8 | Using the Universal Brackets | 15 | Side Net / Replacing the Side Panels |

Introduction to Assembling Your Case

It's not rocket science, but our cases can be slightly more challenging to assemble because we don't follow the typical mass production oriented design but instead try to offer greater flexibility and designs that break the mould. This greater flexibility does however mean component locations are not fixed and therefore overlaps and conflicts can occur, so a bit of extra planning is suggested. It's also important to note that this guide will only show a 'standard' build, but there are many alternative layouts and configurations possible. We do not provide a detailed explanation on any of the advanced options because it does require you to be confident with modding and being able to figure things out for yourself. To avoid frustration, please take the time to read the user guide and become familiar with the product and assembly procedure. Additional information and help is also available on our website or by contacting our support team.

Several different screws will be utilized in the assembly so the user guide indicates which screws should be used and their corresponding fixing location. Screws are defined by head type, e.g. 'Philips countersunk' and by thread and length e.g. 'M3x6', and will be labelled accordingly, e.g. PCS-M3x6. For the standard assembly you will only need a Philips screwdriver, but if you plan on a more advanced build such as flipping the motherboard orientation, you will also require a Hex screwdriver, both 2 and 2.5mm are suggested (depending on what needs to be disassembled)

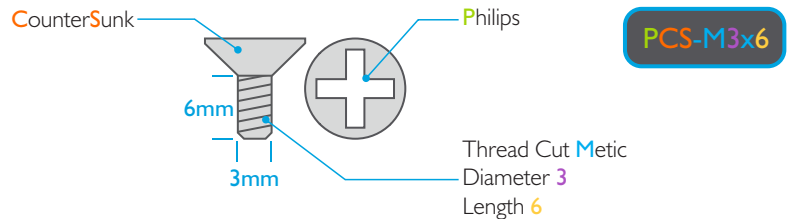

COPYRIGHT NOTICE

Copyright © 2018. All Rights Reserved. No part of this publication may be reproduced, stored in a retrieval system, or transmitted, in any form or in any means – by electronic, mechanical, photocopying, recording or otherwise – without prior written permission. All trademarks and registered trademarks in this publication are the property of their respective owners.

Specification

Form Factor: SFF Mini Tower
CPU Cooler Max Height: 145mm
PCI Support: Dual Slot, 330 x 150 x 50mm (LxWxH)
Fan Support: 40 to 180mm, 92mm (Rear)
Drive Support: 3 x 3.5" or 6 x 2.5" (per Bracket)
PSU Support: SFX, SFX-L and ATX^{*1}
Dimensions: 340 x 286 x 180mm, 17.5ℓ

Motherboard Support: Mini-ITX
Water Cooling Support: 120 to 280mm
Front Port: USB Type-C (3.0 ungradable to 3.1)
Primary Material: Aluminium 6063
Finish: Sandblast, Silver or Black
RGB Lighting: Seriously? No!
Weight: 3.9kg

^{*1}Will limit maximum GPU length to 220mm

Overview

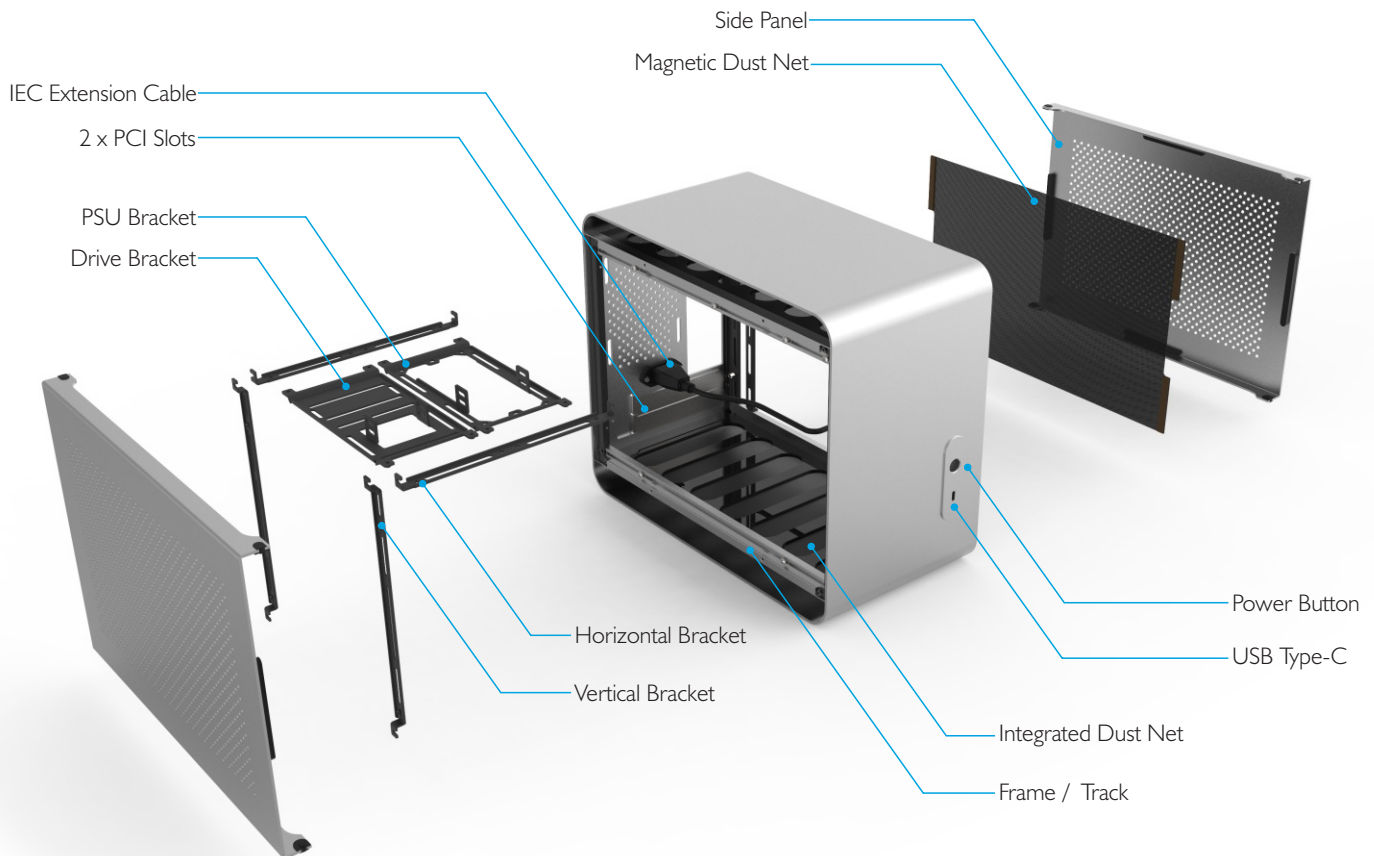

Remove the Side Panels

The side panels are held in place with a simple rubber catch located on each edge (4 per side panel) that locks against the upper and lower frame of the case. To remove the side panel, pull the lower edge away from the case whilst applying pressure downwards to the upper edge. Once the lower edge has cleared the frame, the side panel will be loose and free to pull away from the case. The key point to note when removing the side panel is to only pull against one edge of the panel and not both at the same time. Both side panels are symmetrical and interchangeable.

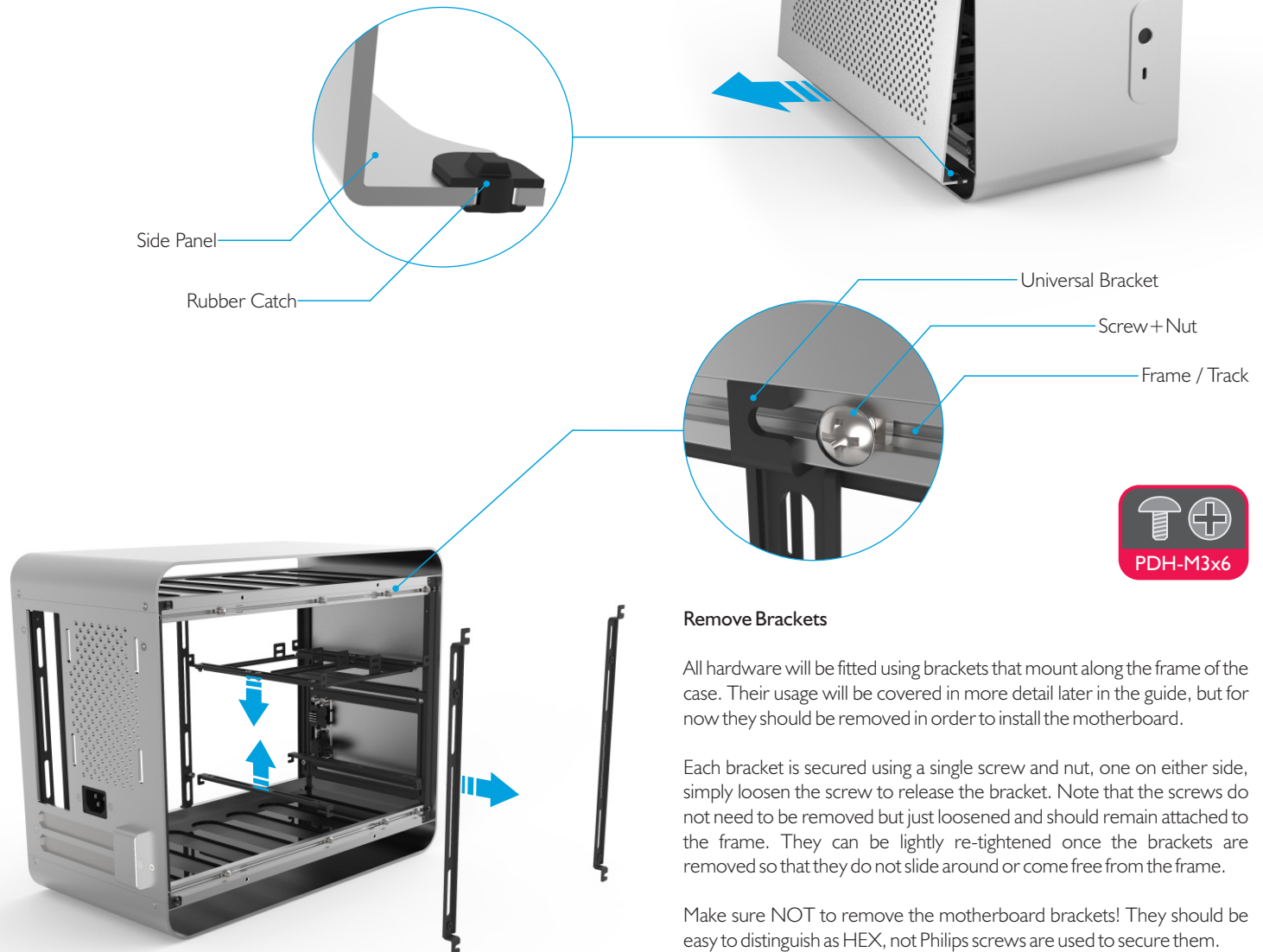

Remove Brackets

All hardware will be fitted using brackets that mount along the frame of the case. Their usage will be covered in more detail later in the guide, but for now they should be removed in order to install the motherboard.

Each bracket is secured using a single screw and nut, one on either side, simply loosen the screw to release the bracket. Note that the screws do not need to be removed but just loosened and should remain attached to the frame. They can be lightly re-tightened once the brackets are removed so that they do not slide around or come free from the frame.

Make sure **NOT** to remove the motherboard brackets! They should be easy to distinguish as **HEX**, not Philips screws are used to secure them.

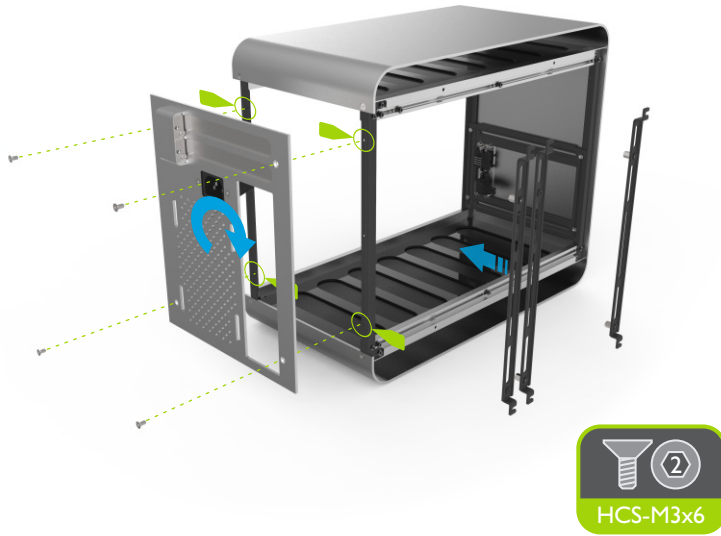

Mounting Above the Motherboard (Optional)

The space above the motherboard can also be utilised for mounting hardware such as fans, but due to the tight tolerances between the motherboard and frame, the brackets for this specific location must be installed prior to installing the motherboard.

The spacing of the horizontal brackets does also need to be taken into consideration as the motherboard brackets already occupy specific positions that might conflict with the spacing required for the hardware being fitted there.

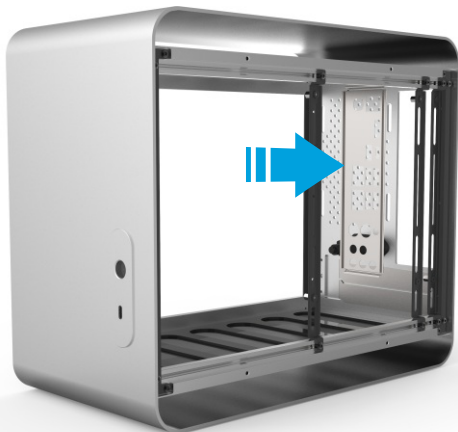

Motherboard Orientation (Optional)

Not part of the standard installation procedure, but worth noting that the motherboard orientation can be flipped should that provide some specific advantage to your planned build.

This is achieved by removing 4 screws which secure the back panel to the frame, rotating it 180 degrees, then replacing the 4 screws. In addition, the motherboard brackets need to be moved to the other side of the case in their corresponding location. This procedure will require a 2mm HEX screwdriver. There are some markers printed on the edge of this page back page that indicate the correct spacing for the motherboard brackets.

Default -  Flipped - 

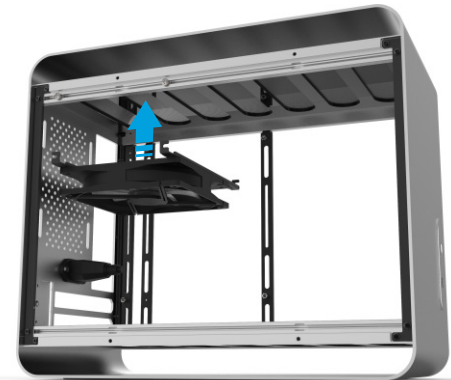

Install the Motherboard I/O Shield

Locate the I/O shield supplied with your motherboard and firmly push it in place from the inside of the case, making sure the orientation is correct. It's important to make sure it is properly fitted otherwise the motherboard will be difficult to install and not align correctly with the stand-offs.

Prepare the Motherboard

Whilst it is possible to populate the motherboard with components once it's fitted inside the case, it is generally easier to fit the CPU, RAM and cooler prior to this. Please refer to the user guides supplied with each component for exact installation procedure as the image below is just for reference.

If using an AIO water cooler, we recommended installing it after all the other hardware has been fitted to the case. The tubing and radiator will make working with the case more difficult and as the radiator will typically be mounted to the side, fitting it will obstruct the installation of other components. You can still fit the mounting mechanism but even if you don't, there is unobstructed access to the back of the motherboard so this can be done later.

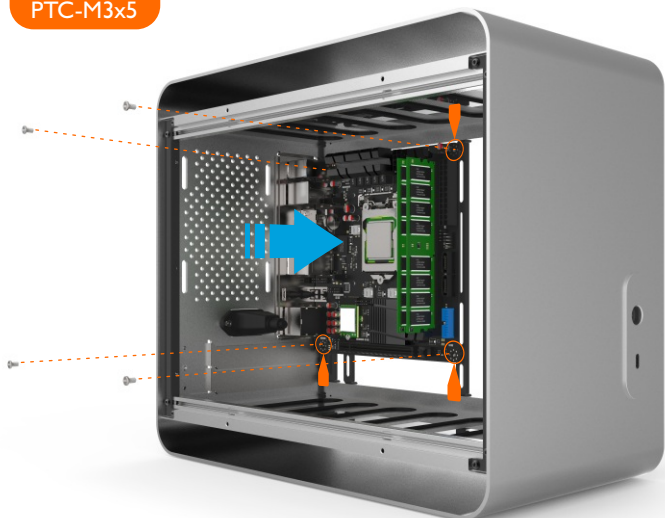
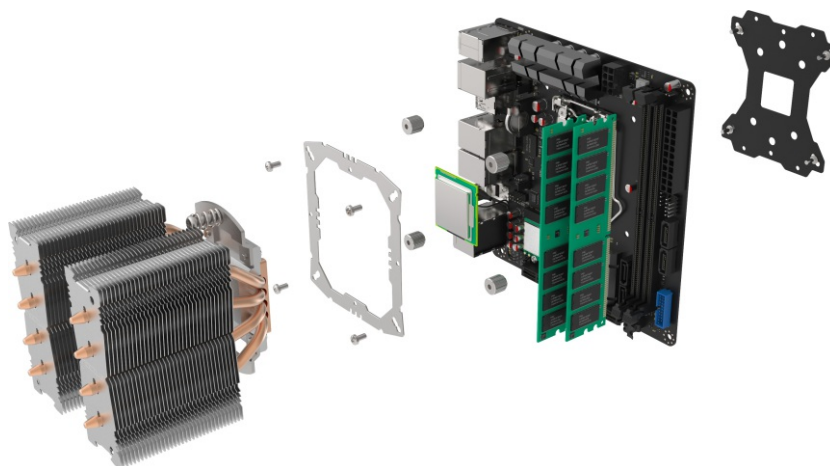

Install the Motherboard

Carefully lower the motherboard into the case, with the rear I/O port side first so that the ports align with the matching cutouts on the I/O shield.

When the motherboard is correctly in position, secure it to the stand-offs on the universal brackets using the screws provided. Ensure that all the holes correctly align before fully tightening the screws.

Note that the use of universal brackets means there is almost no obstruction to the back of the motherboard so M.2 cards, for example, can be added or changed with ease.

Introduction to the Universal Bracket

The universal bracket is a concept we originally introduced on the F12C and DB4 cases. The basic idea is that any and all hardware can be fitted to a universal bracket (hence the name universal) which can then be located anywhere along the frame of the case. This approach gives incredible flexibility to the component layout and improves hardware compatibility, but does require additional planning as the lack of dedicated bays can create component overlaps if not properly considered. Each bracket is held in place by a screw and nut at either end, which is captive by the track in the frame and can slide along the entire length. Nuts can be added or removed using the 2 cutouts in the frame to allow for additional brackets or relocating them as required.

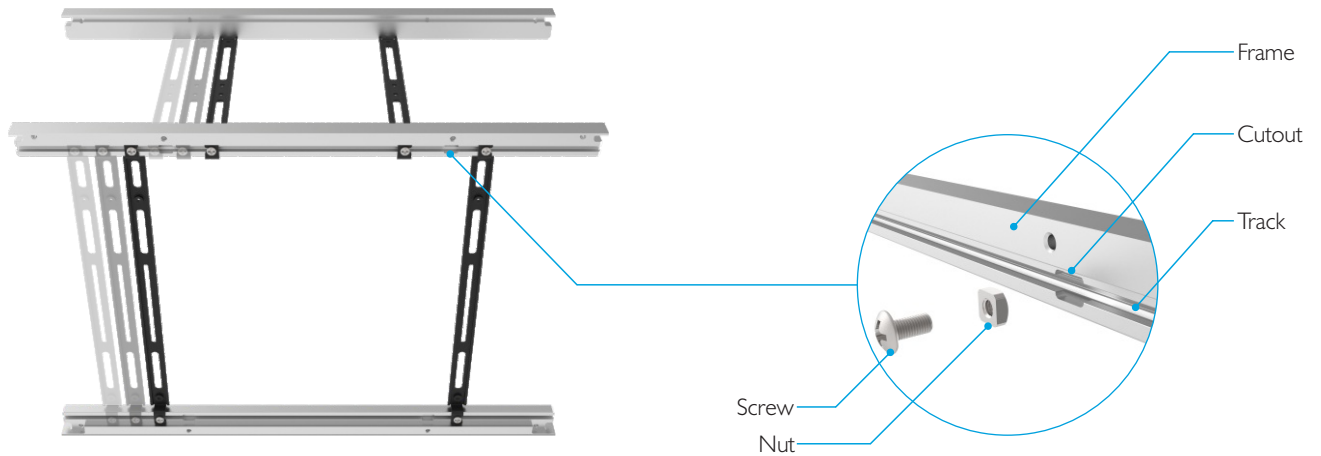

There are 2 sizes of universal bracket supplied, the Vertical that mounts along either side of the case and the Horizontal that mounts to the upper and lower sides of the case. The brackets have holes for pre-defined hardware locations such as the motherboard, and slots that allow hardware to be fitted anywhere along the length. The inner slot on the Vertical bracket is narrower and designed for M3 screws whilst all the other slots are wider to allow for fan screws, but washers are supplied to allow M3 screws to use the wider slots.

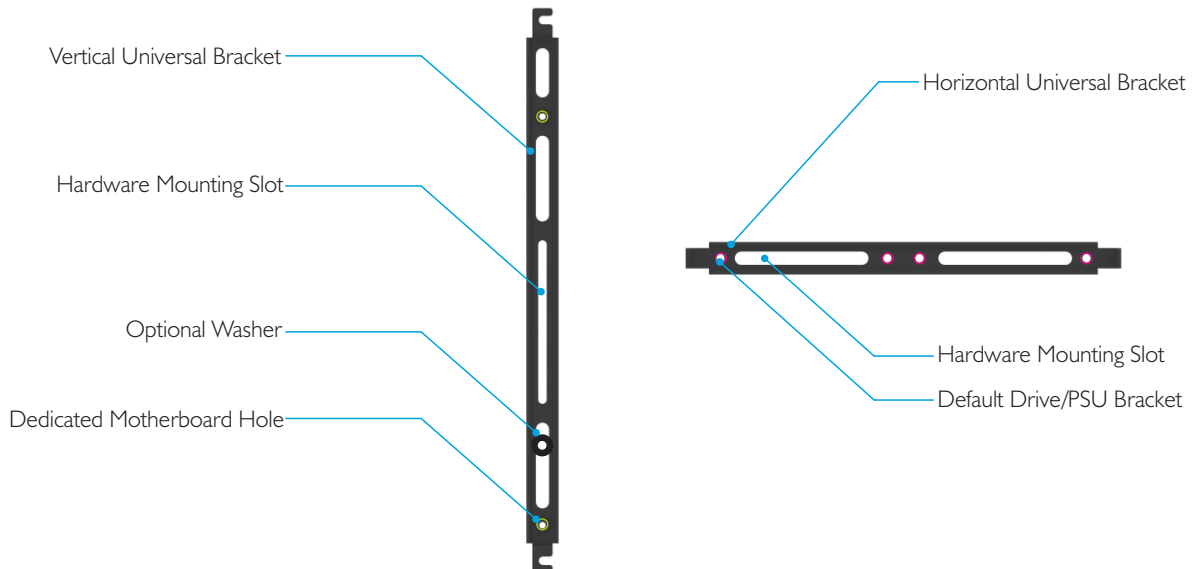

Using the Universal Bracket

The universal brackets are incredibly versatile and in principle, there is no wrong way to use them, the main limitation is the space available and how creative you want to get. Fan screws and washers are supplied but typically the hardware being mounted will be supplied with the correct screw thread and length. Below are just a few examples of what can be mounted using the vertical brackets, with the bottom row showing the horizontal bracket usage.

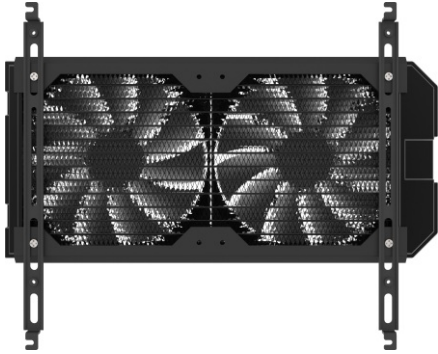

280mm Radiator



140mm Radiator



180mm Fan

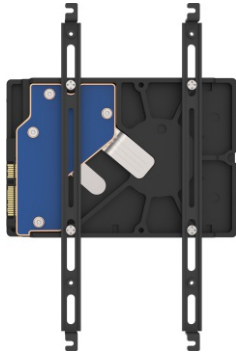

3.5" Drive



150mm Reservoir

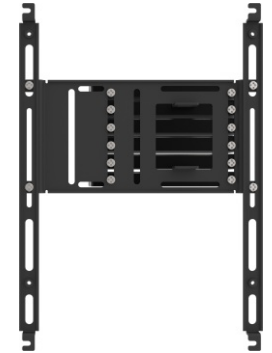

2.5" Drives (with drive bracket)



3.5" Drives



Water Pump

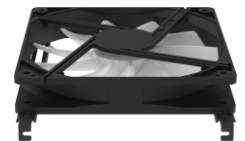

140mm Fan

Drive and PSU Brackets

In addition to the universal brackets, there are 2 dedicated brackets included, the PSU bracket which supports SFX/SFX-L, and the Drive bracket which can accommodate 3 x 3.5" or 6 x 2.5" drives and of course a mix of both (each 3.5" drive occupies the equivalent space of 2 x 2.5" drives). These additional brackets come fitted to the horizontal universal brackets using pre-defined mounting holes, but they can, of course, be re-arrange or mounted anywhere along the bracket and even fitted to the vertical bracket if needed. They can also be used in combination to mount an ATX PSU using the ATX slots and 3 screws (the 4th hole will not be required) but this is at the expense of drives and maximum expansion card length as it will occupy additional space.

PSU Bracket

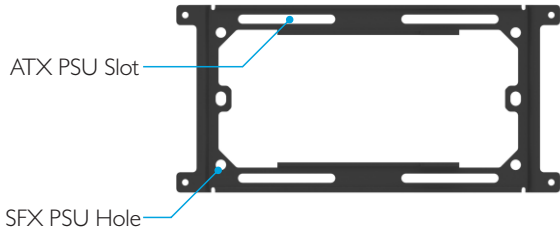

Drive Bracket

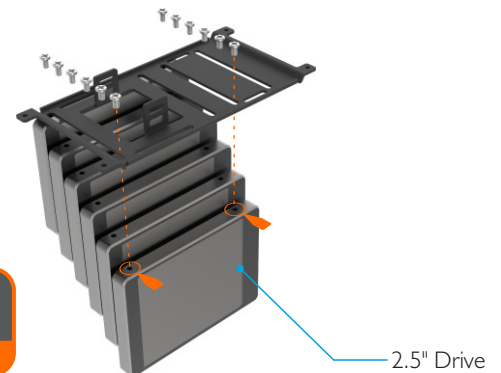
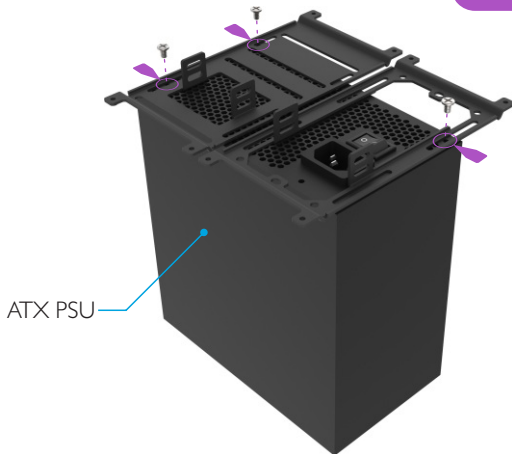
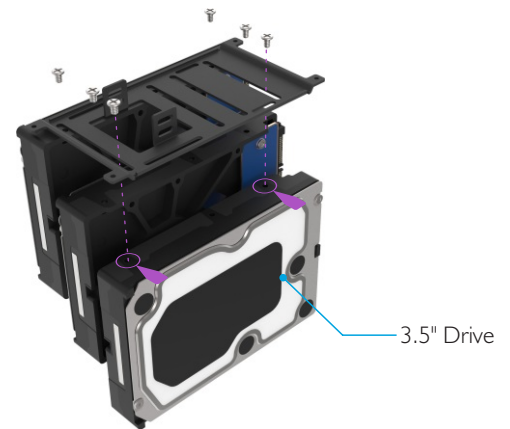
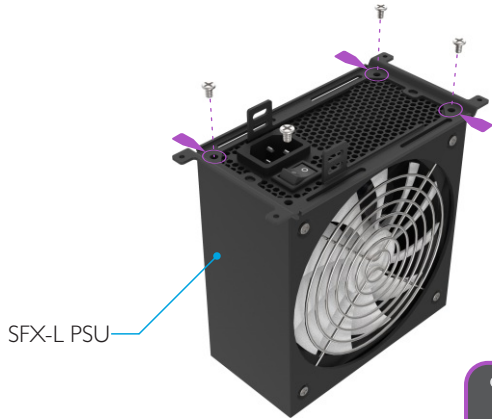
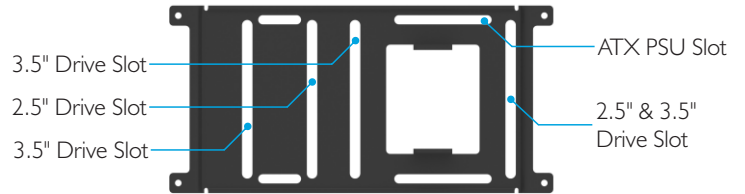

Fit the PSU and Drive Brackets

Fit the PSU and drives to the brackets then install the completed assembly back into the case. Note that we recommend using a modular power supply as this will help with cable management in the confined space. Custom cables are also a great idea if possible to further improve the cable routing and airflow. Don't forget to connect the IEC plug to the PSU and turn it on before you fit the assembly into the case as you will not have access to the socket or switch once it has been fitted.

Now is also a great time to tidy up the cables in preparation for fitting an expansion card and the final step of fitting vertical bracket hardware. Note that the PSU and Drive brackets have some cable tie points to assist with cable management. If the IEC plug conflicts with the cable tie points on the bracket, simply rotate the bracket 180 degrees.

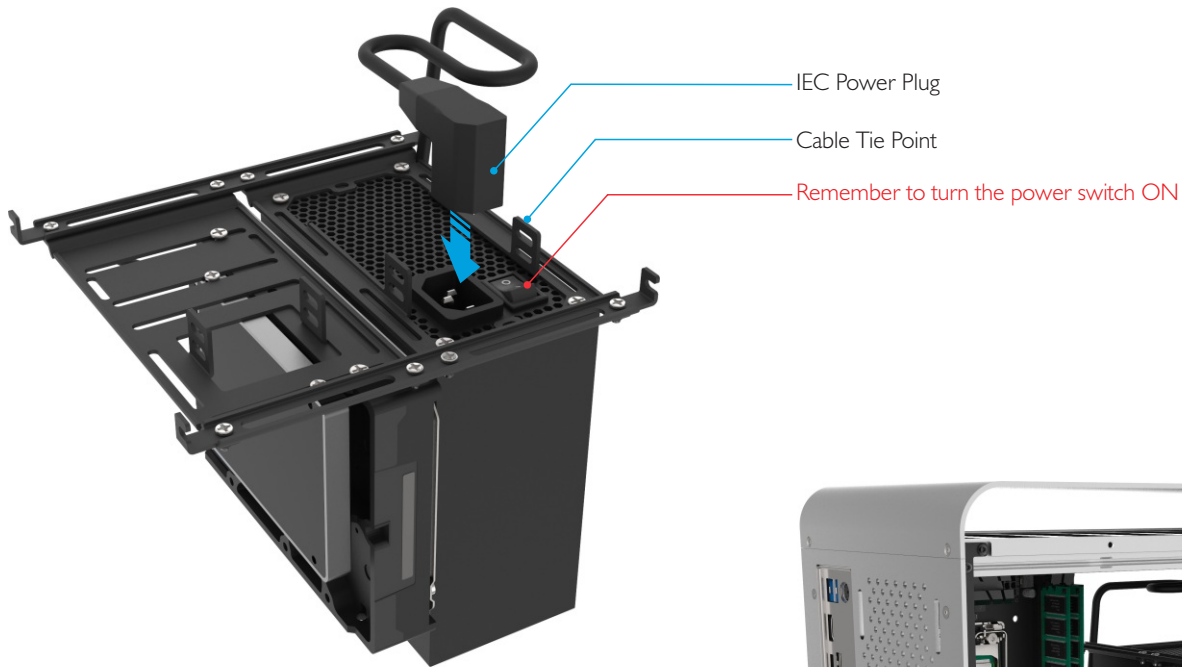

When fitting the brackets, there is no need to work against gravity, simply lay the case on its side or even upside down, to make the installation easier. Make sure to secure the screws on both sides of the brackets.

The power switch / LED cable and USB cable can also be connected to the motherboard at this time, see diagram on next page for wiring details.



Connect the Front I/O Power Switch / LED and USB

Motherboard layout and pinout shown are for illustrative purposes only, these will vary between model and manufacturer, so please check the supplied user guide for exact connection details.

When connecting the power LED, ensure correct polarity otherwise the light will not illuminate. The orientation/polarity of the power on/off switch (PSW) is not important and can be ignored, and the connectors are individual to allow for motherboards that use a 3 Pin layout. A reset switch is not included, but holding down the power button for 5 seconds usually serves the same function. Drive activity is also not included, this is a legacy feature we have chosen to omit.

The 19 PIN USB3.0 connector is polarised and will only connect in the correct orientation. A planned optional upgrade for USB3.1 Gen2 will be made available in the form of a new USB cable which can be installed by removing the 2 Hex screws securing the Type-C connector to the front I/O, then fitting the new cable. Both the Switch / LED PCB and the USB Cable can be rotated 180 degrees on the front I/O to route the cables in the opposite direction if there if you have a requirement for that in your specific build.

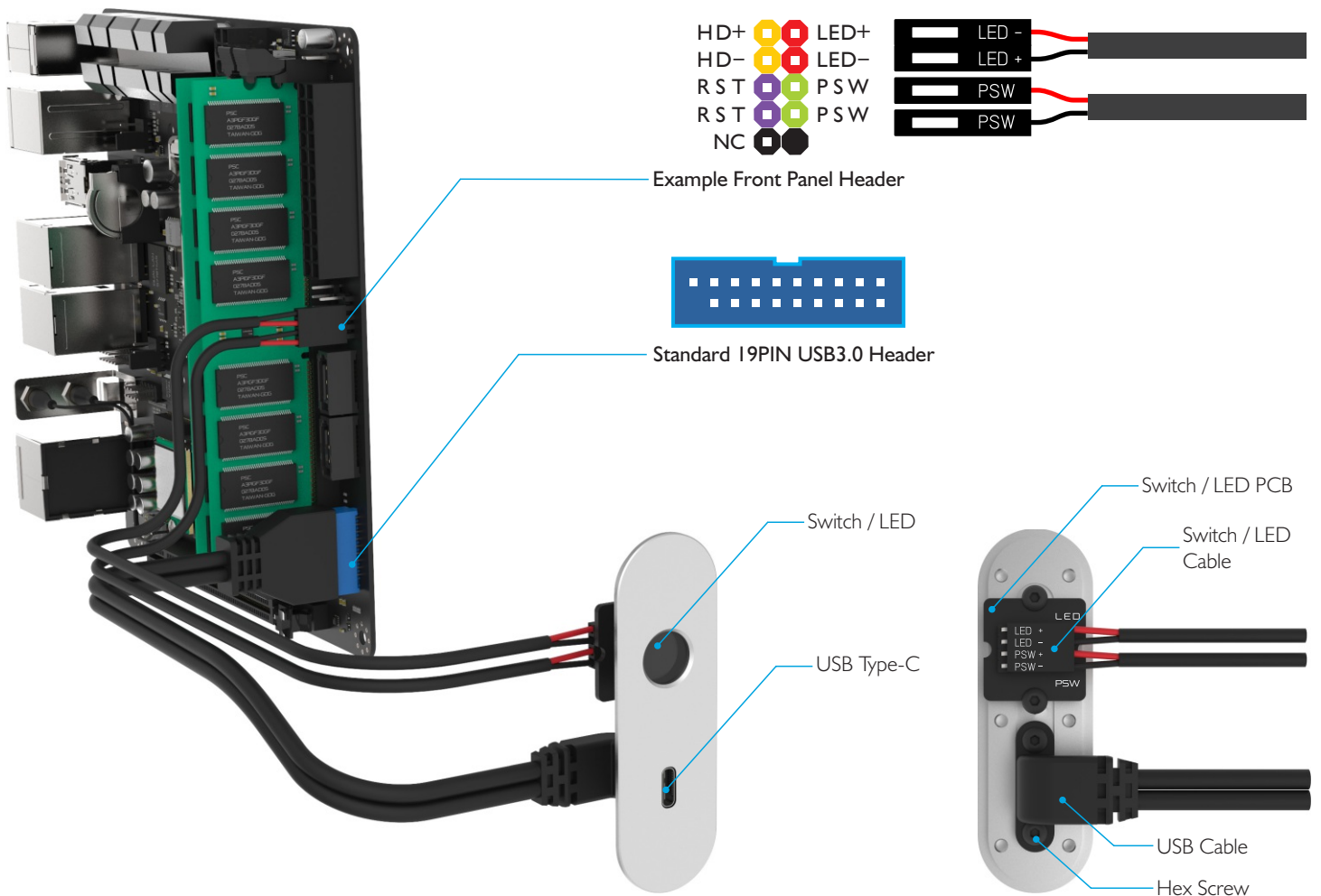

Install a PCI Expansion Card

The DA2 supports a full-length dual slot expansion card. To install a card, begin by removing the pre-installed PCI blanking plates which are secured to the PCI mount by a single screw for each plate. From the inside of the case remove the single screw which secures the PCI mount to the back of the case. The brackets and PCI mount will now be loose and can be removed from the case.

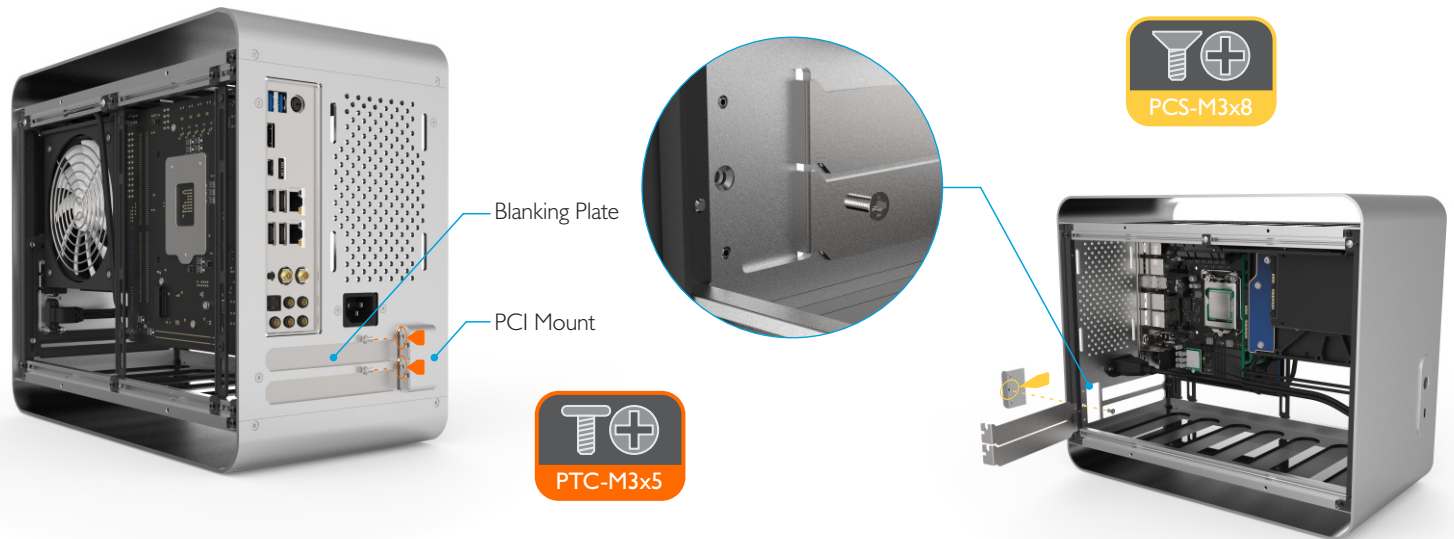

Align the expansion card with the edge of the motherboard PCI slot at an angle so that the back of the card clears the PCI mount opening, then slowly insert the card so that its correctly seated in the PCI slot. The card is then locked in place by replacing the PCI mount using the same single screw from the inside, then attaching the card to the PCI mount.

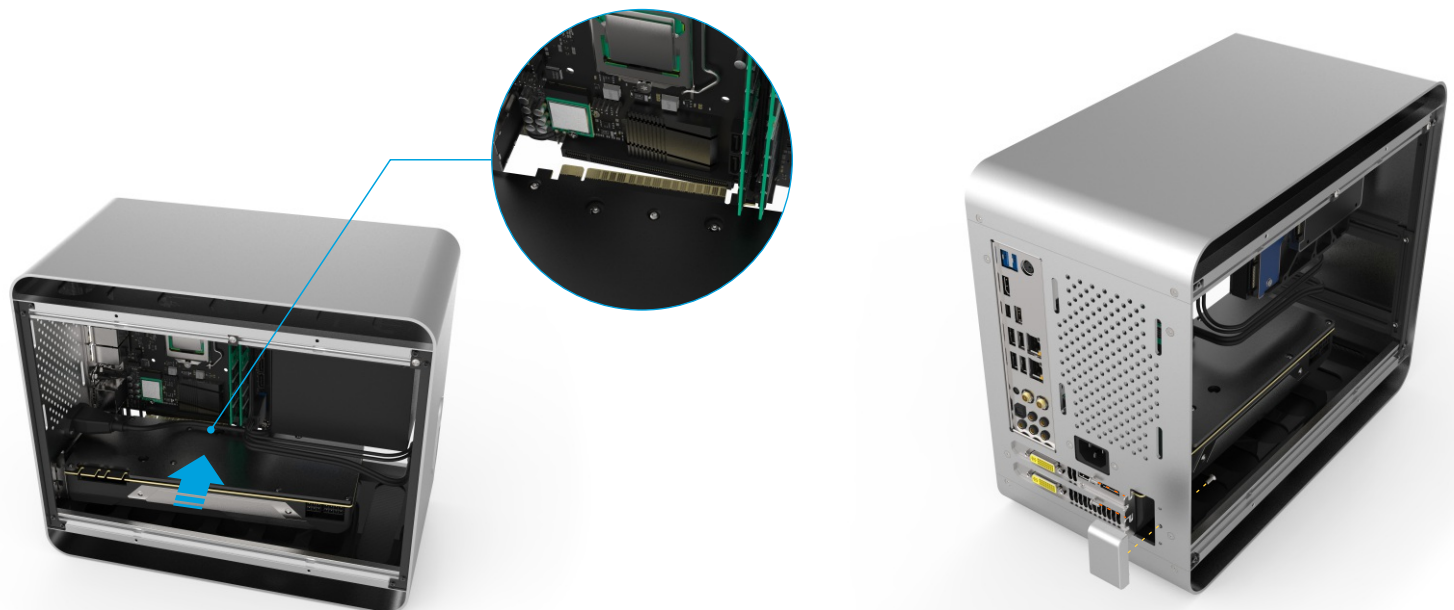

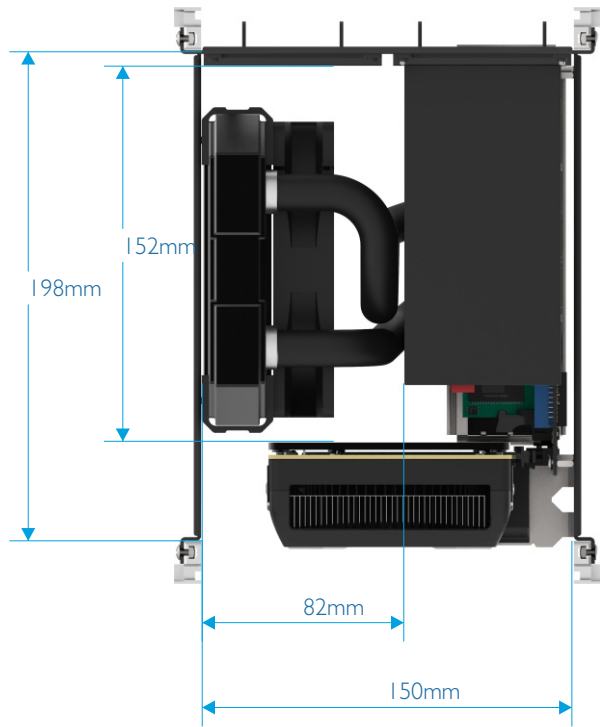

Install Vertical Bracket Hardware (AIO Cooler Example)

The images on page 8 show some examples of hardware that can be fitted on the vertical brackets. For this specific example, we will demonstrate fitting a 240mm radiator, but the same principles apply to any other hardware being fitted.

A key element when planning and using the brackets is to consider how much space is available behind them. Typically a SFX PSU will be used which leaves 82mm of clearance for the radiator. It is therefore important when choosing a radiator to consider the radiator thickness + fan thickness + tubing, so make sure it can fit within that space.

The dimensions shown in the example are absolute maximums, so it is also worth allowing a few mm of additional space for tolerances.

Once you are confident that everything will fit, attach the vertical brackets to the radiator using the screws supplied with it. Apply thermal paste then fit the CPU block to the motherboard. Connect the pump and fan cables, then attach the radiator to the frame using the screw+nut in the appropriate location. You can always adjust the exact position of the radiator along the frame tracks and bracket slots.

It's also recommended to make sure all the cables are properly routed and tied down to avoid contact with the fans, and that everything has been connected as access will be blocked by the radiator.



Cooling Strategy

There is no single solution that is going to apply to every build, but there are general principles to consider when aiming for optimal cooling. Of course, a lot is going to depend on the CPU, GPU, cooling hardware and the application, so all these must also be factored in.

The standard approach will be to draw cool air from the lower and right side of the case and vent it towards the left, rear and upper sides of the case. If using a top-down cooler it will likely be drawing air in from the left side, so adding a fan above the motherboard or a rear fan could aid with removing the warm air inside the case.

The orientation of the PSU should also be considered, it can either operate in an isolated way, drawing air from the right side or be used to draw air from inside the case, potentially reducing heat build-up, especially from the drive area.

It is also worth evaluating if a negative or positive case pressure setup is going to work best and considering the various associated pros and cons.

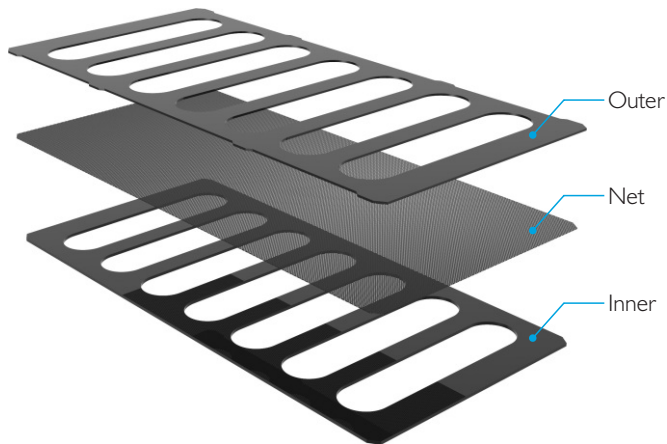
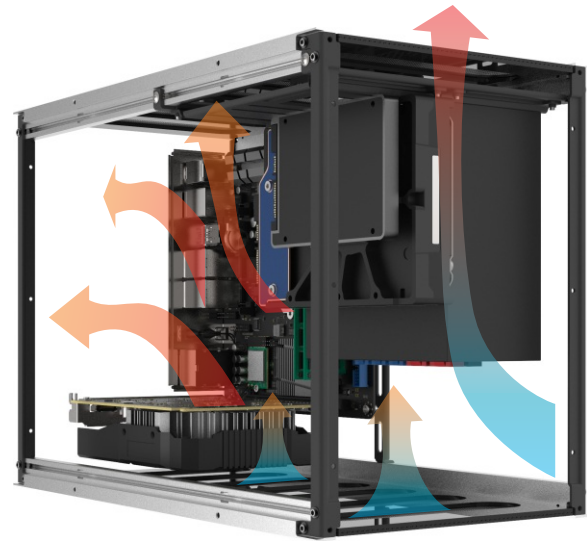

Upper/Lower Dust Nets

The upper and lower sides feature an integrated net which is sandwiched between outer and inner acrylic sheets. The net can be removed for cleaning by first removing the outer acrylic sheet which has a slightly different cutout and is thinner, making it easier to bend. Flexing the outer sheet so that it bends in the middle will allow it to clear the inner track of the frame and be removed from the case. Do not apply too much force when bending, even though the material is flexible, it can crack if too much force is applied. Simply reverse the procedure to replace the acrylic sheet.

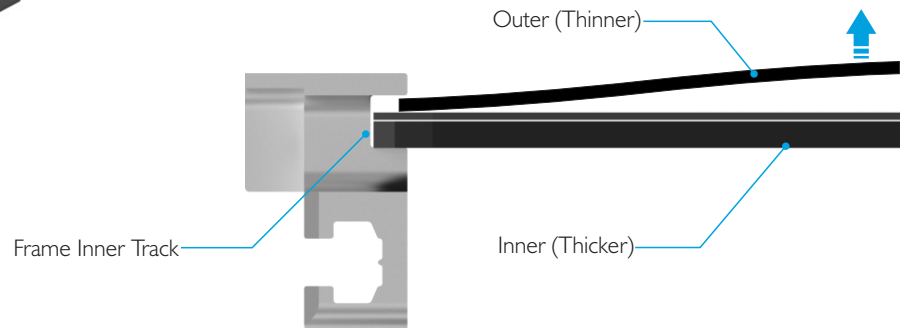

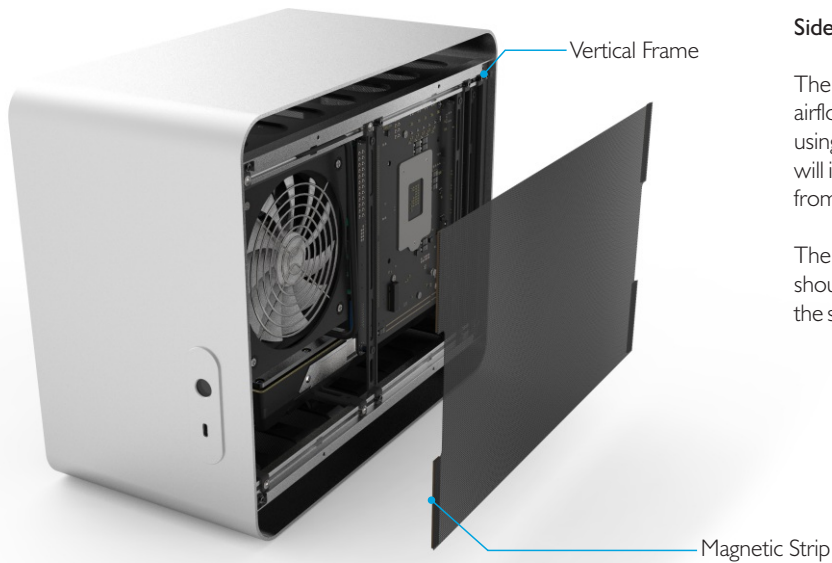

Side Dust Net

The case also includes a side net which can be fitted depending on the airflow and cooling strategy you have implemented. We recommend only using the net if air is being drawn through it from the side panel as installing it will impede airflow and is not required or useful when air is being expelled from the case.

The net is magnetic and will stick to the vertical frame of the case and should be attached centrally between the upper and lower tracks. Fitting the side panel will further secure the net to the case.

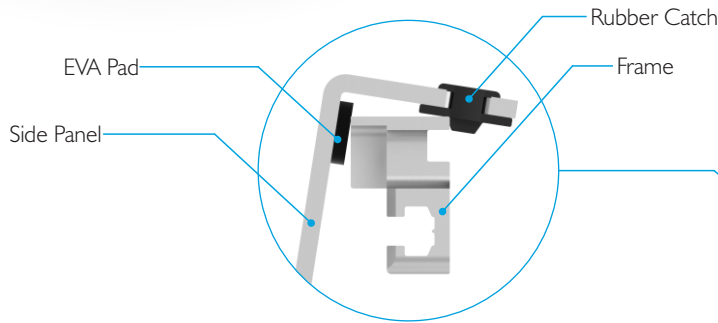

Final Inspection and Replacing the Side Panels

With the case now fully assembled, take one final look to make sure all the universal bracket screws have been correctly tightened, all the cables have been connected and that there is nothing loose that could make contact with the fans.

The side panels are replaced by resting the upper edge on the top frame of the case, then pushing the lower edge onto the bottom frame until it sits flush with the edge of the case.

When resting the upper edge of the side panel, make sure the rubber catch is correctly positioned on the frame otherwise it will be difficult to push the lower edge onto the bottom frame.



